

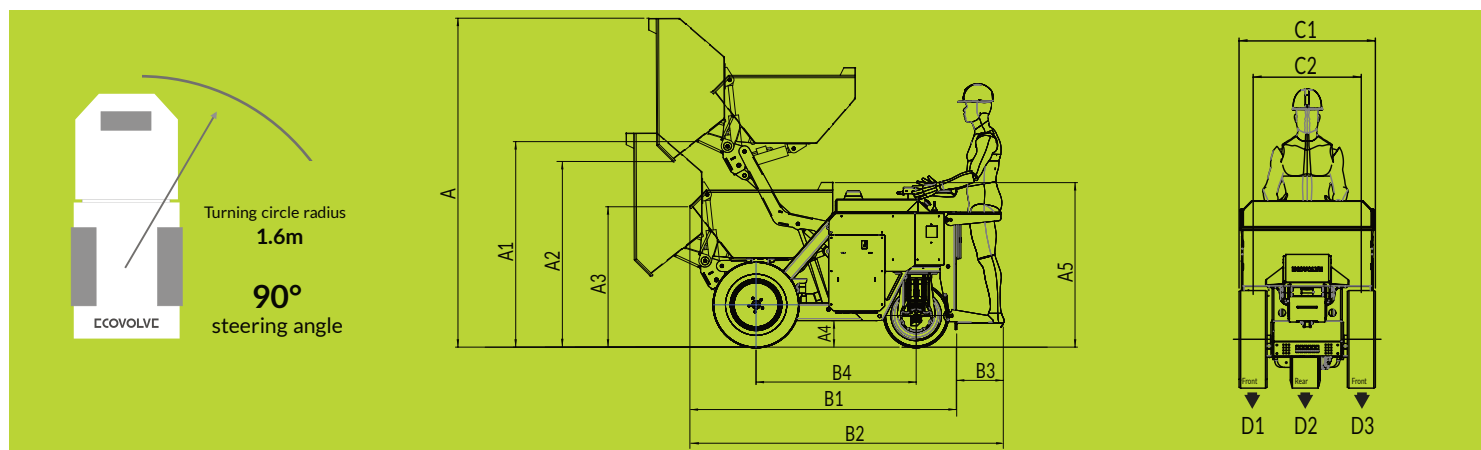

		ED800	ED1000	ED1500
Capacity	Max safe load (Kg)	800	1000	1500
	Unladen weight (Kg)	1200	1200	1500
	Skip - Levelled (Ltr)	350	435	575
	- Heaped (Ltr)	480	600	800
	- Water level (Ltr)	225	315	460
Drive	Drive type	1 wheel drive	1 wheel drive	3 wheel drive
	Steering	1 wheel steer	1 wheel steer	1 wheel steer
	Speed (Km/h)	0-6	0-8	0-8
	Steering angle	90°	90°	90°
	Grade ability	15°	15°	15°
Transmission	Proportional Steering	Drive	Drive	Drive
	Tires - Front (2no. Super elastic)	27x8,5x15	27x8,5x15	27x8,5x15
	- Rear (1no. Super elastic)	21x8x9	21x8x9	21x8x9
	Brakes	Dynamic electric brake Negative parking brake		
Hydraulic system	Gear pump - Flow rate (Ltr/Min)	5.5	5.5	6.5
	- Oper. pressure (Bar)	130	130	150
	Pump motor (KW)	2.2	2.2	2.2
	Hydraulic tank capacity (Ltr)	2.8	2.8	5
Electric system	Voltage (V)	24	24	24
	Battery (KWH)	9.6	9.6	14.4
	Integrated Charging - Input (V AC)	100-240	100-240	100-240
	- Output (V DC)	50.0 A	50.0 A	100.0 A
	Recharge (Hrs)	8	8	10
Drive motor	Type	Induction motor		
	Output	5KW/7HP	5KW/7HP	5+4KW/11HP
	Emission	Zero	Zero	Zero
Noise	Driving (Db)	65	65	65
	Buzzer [adjustable] (Db)	60-80	60-80	60-80



[mm]												Unladen		Laden		
	A	A1	A2	A3	A4	A5	B1	B2	B3	B4	C1	C2	D1/D3	D2	D1/D3	D2
ED800	2610	1630	1470	1120	180	1310	2060	2390	340	1210	800	590	280 kg	635 kg	650 kg	700 kg
ED1000	2610	1630	1470	1120	180	1310	2060	2390	340	1210	990	780	280 kg	635 kg	650 kg	700 kg
ED1500	2870	1790	1600	1120	200	1340	2250	2580	340	1330	1160	970	375 kg	750 kg	1125 kg	750 kg



Low Noise



Zero Emissions



High-Tip



< 1.2 Meter Wide



ED800 / 1000 / 1500 BATTERY HIGH-TIP DUMPER

The dumpers are available in three different weight capacities 800 kg, 1000 kg and 1500 kg. There are no emissions, low noise and the drive system significantly reduces the risk of unwanted tyre marks. What's more is that the super elastic tyres eliminate the possibility of puncture, making the ED Range suitable for both indoors and out.

The largest in the range, the ED1500, is still less than 1.2 meters wide with a turning circle of just 1.6m. All 3 have been designed with tight spaces in mind. The superior battery pack will provide power for a full working day on just an 8-hour charge.

The compact size and turning circle means the ED can go where others can't.